



Precoat filter systems

for fine filtration of oils, synthetic grinding fluids, solutions and industrial circulating water

- Compact design due to modular system
- Regeneration / backflushing
- Filter cake drying
- No fabric clogging
- High filter candle strength

Liqui
FILTER

pure. clean.

System specification

The filter system works in accordance with the precoat principle and can be operated with and without filter aids (without filter aids: slotted screen filter AF special system).

The stainless steel wire or plastic elements inside the filter casing are used as filter cake carriers.

The filter aid for precoating is homogenised in a precoating tank with suitable precoating liquid (filtrate or slurry) and applied to the filter elements by a pump in a closed loop. The liquid is circulated over the elements until the filter cake has formed and the liquid emerges completely clear from the filter. Then it is permissible to switch to slurry infeed and filter discharge.

During the filter process, the slurry is pressed through the filter cake and cleaned and clarified. Particles up to 1 µm fineness can be filtered out in this process depending on the type of precoated filter aid.

Small quantities of filter aids can be added continuously when filtering heavily contaminated liquids in order to maintain the porosity of the filter cake.

If the maximum permissible pressure is reached during increasing contamination of the filter cake, the filter shall be cleaned by regeneration.

Discharge and backflushing occur simultaneously. The feed pump is switched off if this pressure is exceeded.

Diagram of Liqui precoat filter

- 1 Filter outlet
- 2 Elements
- 3 Filter inlet
- 4 Filter drain cap
- 5 Flushing connection

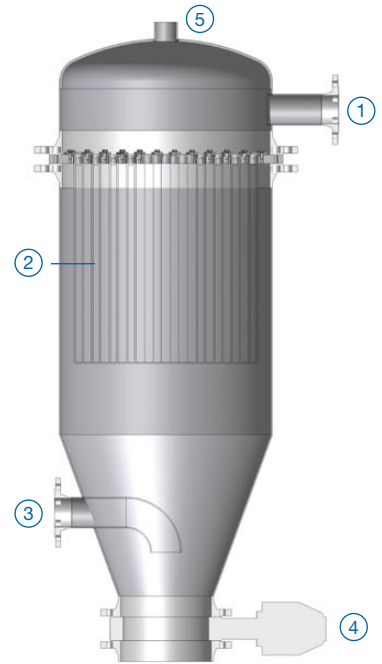

Filter aid selection

The filter aid selection is essential for the clarification effect. Consistent, uniform quality, correct particle shape and size and minimum moisture content are important. Kieselguhr and cellulose fibres have proved to be the best. Correctly processed, they form skeleton-shaped, porous, odd-shaped particles which produce the best filter effect.

Perlite, cellulose fibres and carbon products are also used as filter aids as well as kieselguhr. We recommend the most suitable filter aid individually for each application. 500-1000 g/m² filtration surface is required, depending on the type of filter aid used. Different filter aids can be precoated in special cases.

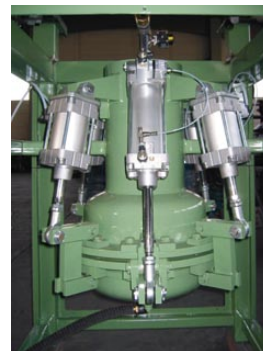

Optional:
sludge drying station

Liqui FILTER

Liqui Filter GmbH

Richard-Stocker-Strasse 19 D-78234 Engen
Tel. +49 7733 9402-0 Fax +49 7733 9402-40
E-Mail info@liqui-filter.de Internet www.liqui-filter.de