

Lifting systems

20 - 2000 l/min

optional: integrated chip cutter for hydraulic chip delivery

Liqui
FILTER

pure. clean.

Technical data

Type	Tank capacity	Tank Ø	Tank height
HST 40	40 l	480 mm	228 mm
HST 100	100 l	600 mm	350 mm
HST 180	180 l	800 mm	350 mm
HST 350	350 l	1,000 mm	450 mm

Only suitable for short solids up to approx. 20 mm long. We also supply special sizes up to 5 m³ upon request. Pump design dependent on head and liquid.

Lifting station for liquids with short solids up to 20 mm

Transport of contaminated liquids with short solids. Delivery is up to 4000 l/min depending on the model.

Lifting station with integrated chip cutters for liquids with long solids.

Transport of contaminated liquids containing chips over 20mm long. The delivery is up to 5000 l/min with dosed chip feed to the pump.

Optional accessories

- Agitators
- Flange-mounted chip conveyors
- Safety switches to WHG
- Cutter pumps

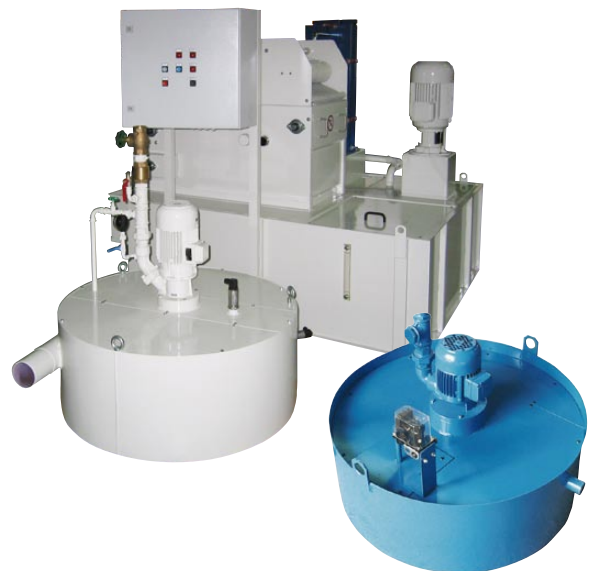
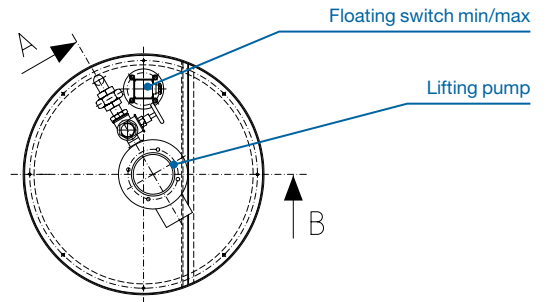
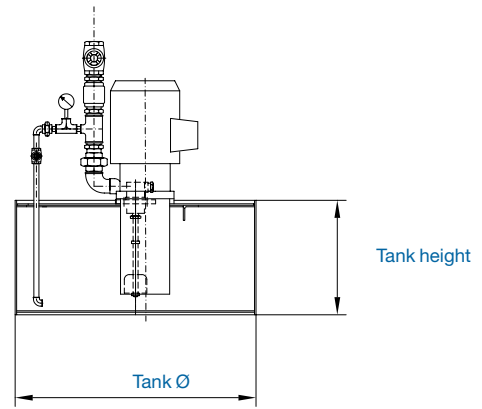
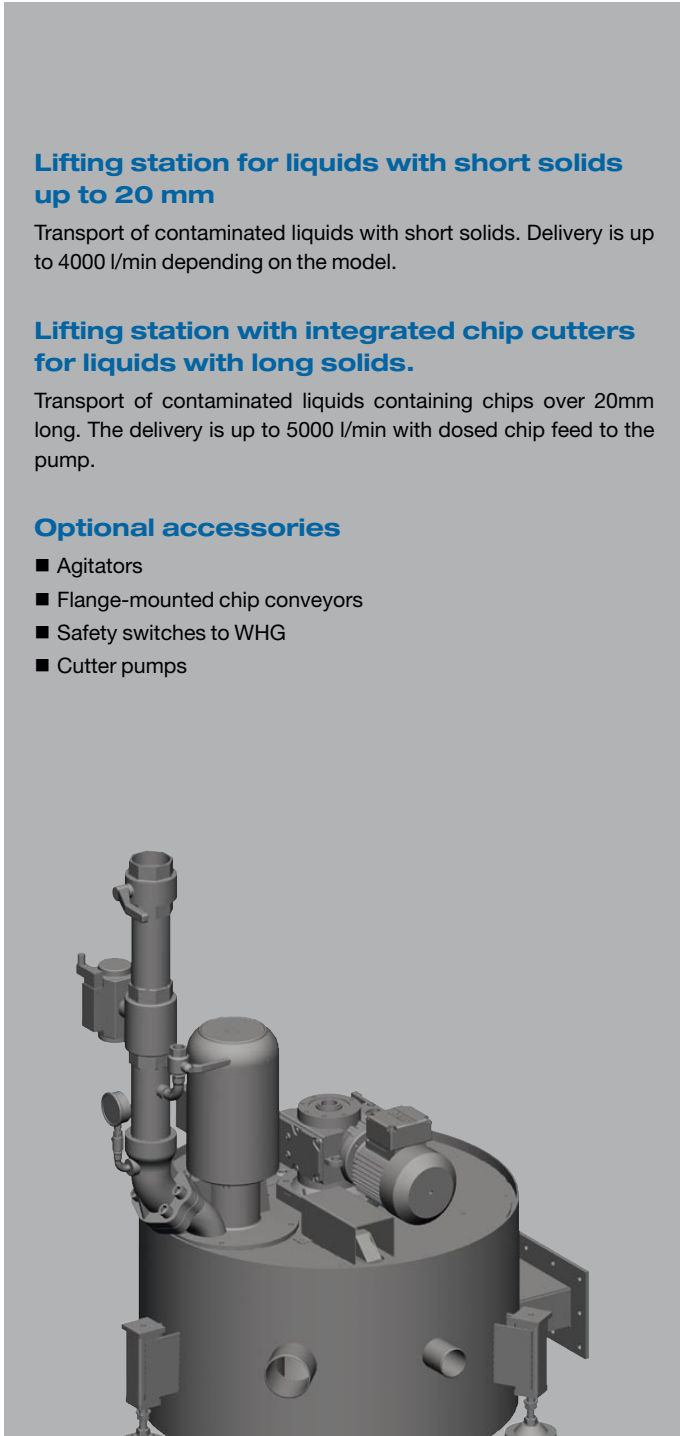

Liqui FILTER

Liqui Filter GmbH

Richard-Stocker-Strasse 19 D-78234 Engen
 Tel.: +49 7733 9402-0 Fax: +49 7733 9402-40
 E-mail: info@liqui-filter.de Internet: www.liqui-filter.de